



## **ST-12 SuperTune 12 Engine Data Acquisition System**



**The Oxygen Sensor used in this device gets very hot in operation. Do not touch the hot sensor. Do not let a hot sensor touch a combustible surface. Do not use the sensor with or near flammable liquids or gases. Failure to heed these warnings may result in severe burns, explosions or fires.**

**When installed in the exhaust, the oxygen sensor MUST be connected and operating with the ST-12 whenever the car is running. An un-powered oxygen sensor will be quickly damaged when exposed to hot exhaust gases.**

1	Overview .....	3
2	The SuperTune-12 (ST-12).....	4
3	First Time Use.....	5
3.1	Launching and connecting LogWorks .....	5
3.2	Connecting the LC-1ST to the ST-12 and Calibration.....	6
3.3	Selecting internal sensors. ....	7
4	LC-1ST.....	8
4.1	Calibration .....	8
4.2	Free air calibration .....	8
4.3	Sensor heater calibration .....	9
4.4	Sensor Location .....	9
4.5	HBX-1.....	11
4.6	Programming the LC-1ST .....	11
4.6.1	Resetting the calibration data.....	12
4.6.2	Updating the Firmware.....	12
4.6.3	Programming the analog outputs .....	12
4.6.4	Advanced output programming .....	13
5	Internal Sensors.....	14
5.1	Connecting Type K Thermocouples.....	14
5.2	Connecting an RPM signal.....	15
5.2.1	Using the Variable Potentiometer.....	15
5.2.2	RPM Measurement basics .....	15
5.2.3	Four-Stroke Engines .....	15
5.2.4	Two-Stroke Engines.....	16
5.2.5	Rotary Engines (Wankel Engine) .....	16
5.2.6	How the ST-12 determines RPM.....	16
5.2.7	Programming the RPM input.....	17
5.2.8	Using the ST-12 with the Inductive Clamp .....	18
5.2.9	Inductive Clamp Usage .....	18
5.2.10	Using the RPM-Converter with pulsed RPM input (Tach) signals.....	19
5.3	Measuring Pressures .....	19
5.3.1	Measuring MAP.....	19
5.3.2	Measuring boost/vaccum .....	19
5.4	Measuring Ignition Advance.....	20
5.4.1	Making your own optical reference pulse sensor .....	22
5.5	Measuring Frequencies, custom RPM, or speed.....	23
5.6	Measuring duty cycle .....	24
6	Programming the ST-12.....	24
6.1	Changing the device name .....	25
6.2	Updating the firmware .....	25
6.3	Input 1 Configuration.....	25
6.3.1	Measuring RPM .....	26
6.3.2	Measuring Frequency .....	27
6.3.3	Measuring Speed .....	27
6.3.4	Duty cycle.....	28
6.4	Input 2 Configuration.....	28
6.5	Input 3 configuration.....	28
6.6	Input 4 configuration.....	29
6.7	Input 5 configuration.....	29

## 1 Overview

The SuperTune-12 is a complete data acquisition system for advanced engine tuning. The system is capable of logging up to 12 Air/Fuel channels and also includes flexible sensors for RPM, MAP, Temperature, Duty Cycle, and analog inputs.

The ST-12 can power, manage, and consolidate data from up to 12 specialized LC-1STs (Lambda Cable) wideband oxygen sensor controller cables. The specialized cables are functionally identical to the standard LC-1ST cables, except they are 18 ft. long, terminated with a single ST-12 (DB-15) connector, and sleeved in a rugged thermal insulator.

The ST-12's LC-1ST is a Wideband Controller used to measure the Air/Fuel Ratio (AFR) or Lambda for an engine. For *gasoline*-driven engines, the theoretically optimal air fuel ratio is 14.7 pounds of air for every pound of fuel. At this ratio, theoretically, all available oxygen in the air combines with all available fuel. This ratio is called the stoichiometric ratio. Stoichiometric for different fuels are as follows:

Gasoline	14.7
LPG (Propane)	15.5
Methanol	6.4
Ethanol	9.0
CNG	17.2
Diesel	14.6

The measurement Lambda is the actual air fuel ratio over the stoichiometric ratio. A Lambda measurement of "1" equates to the air fuel ratio of 14.7 (for gasoline engines). When Lambda is less than 1 the engine runs "rich", i.e., unburned fuel exists in the exhaust stream. If lambda is greater than 1 the engine runs lean, i.e., free oxygen ( $O^2$ ) is present in the exhaust. Depending on the engine, maximum power is typically delivered when the engine runs slightly rich (for example at lambda values of 0.8 to 0.9 for most engines). This instrument provides a means to measure the actual air fuel ratio or lambda in the engine in operation directly from the exhaust. For this a special wide-band oxygen sensor is used to measure the lambda value derived from the oxygen content (or lack thereof) of the exhaust gases.

## 2 The SuperTune-12 (ST-12)

Front View

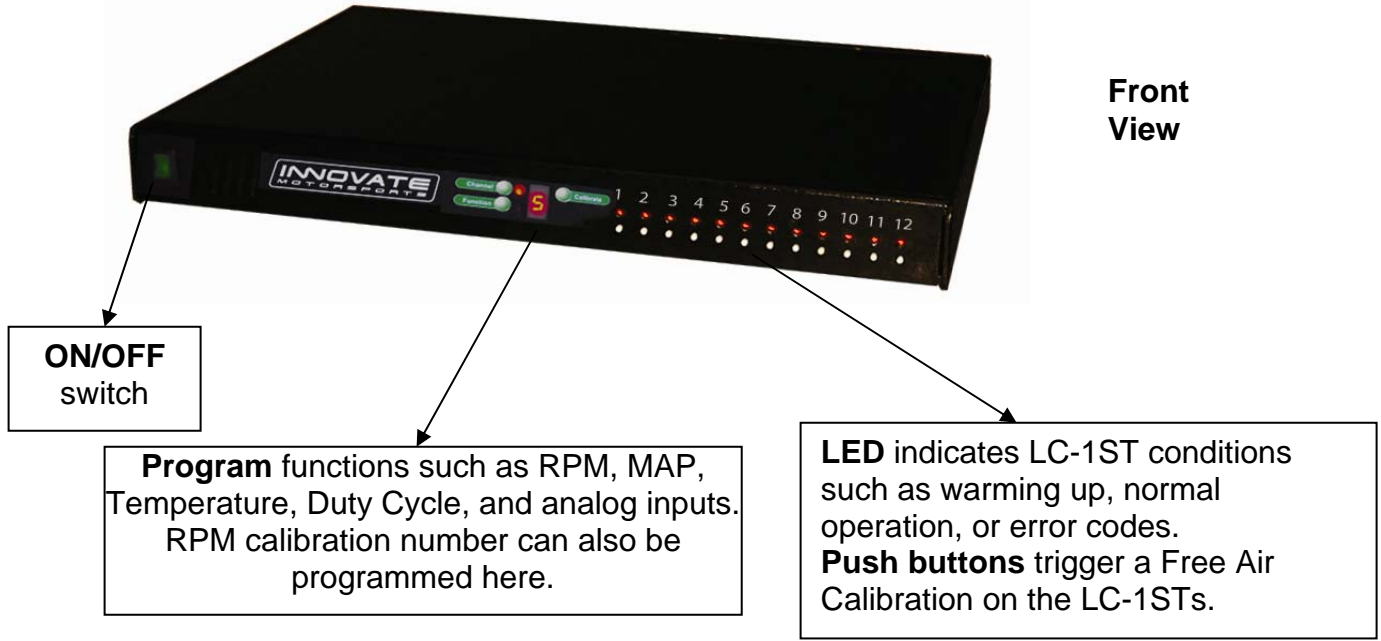

Rear View

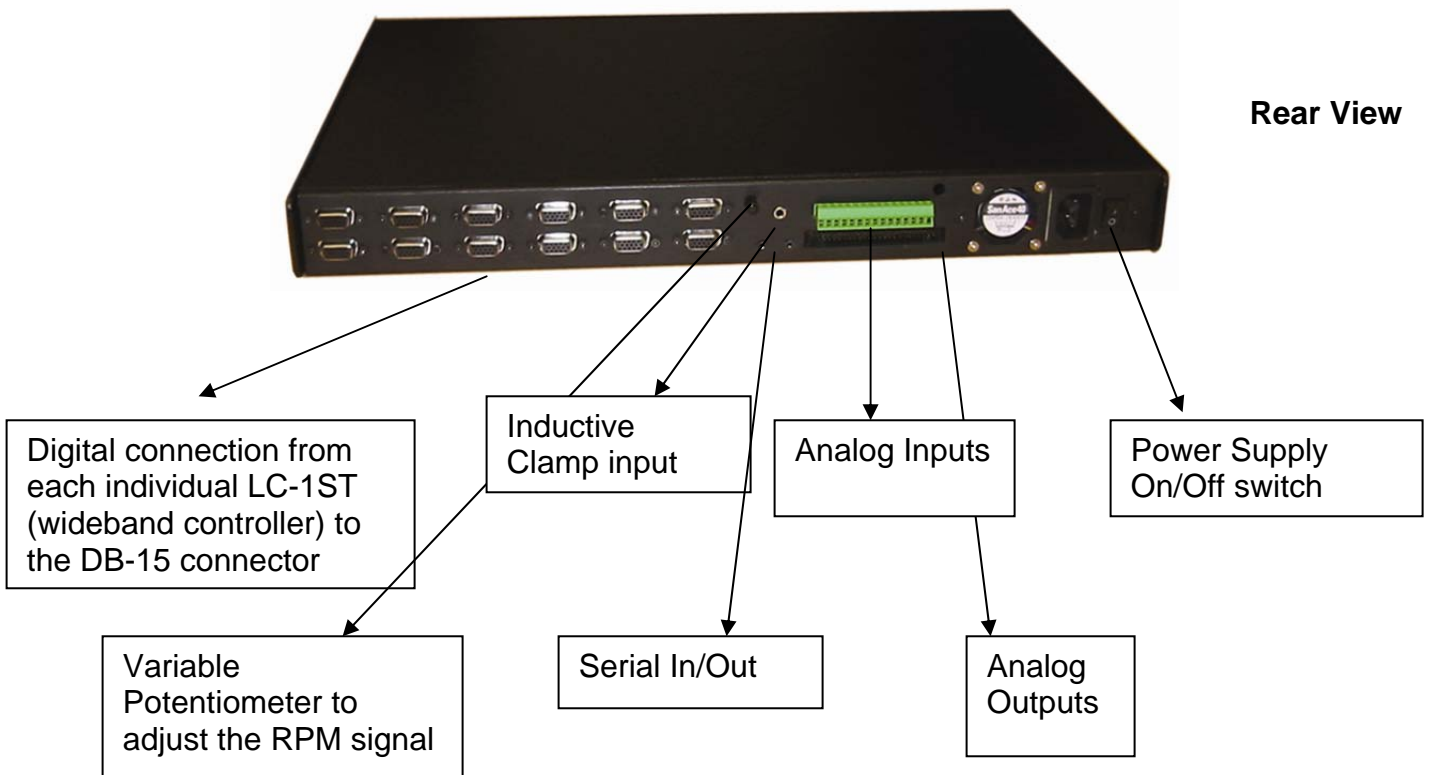

### 3 First Time Use

Put the included CD in your CD-drive on your computer and follow the instructions on screen. The Software will be installed including pre-set directories for log-data and downloaded software. The LM Installer also puts entries for the LM Software in the Start-Menu of your computer under the heading 'Innovate!'.

The following items will be installed on your hard-drive

1. LM Programmer  
This is used to program the analog outputs of the LC-1ST, the fuel type used, the sensor type used, and also allows to 'reflash' the firmware of the LC-1ST.
2. LogWorks  
This is a comprehensive datalogging and analysis package. It also allows real-time logging and display.

#### 3.1 Launching and connecting LogWorks

Connect the Serial OUT port of the ST-12 to a free serial port on your computer and start the LogWorks program.

The following dialog box will appear:

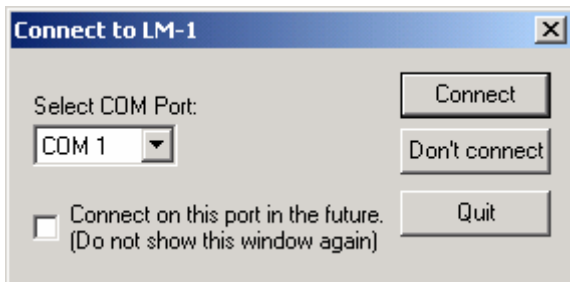

Select the serial port (COM Port) to which the Log-Chain is connected. Then press the Connect button.

To quit here and don't start LogWorks press the Quit button.

If you do not wish to connect to the chain of sensors (or don't have it connected), Press the "Don't connect" button.

Check the "Connect on this port in the future" checkbox if you want to auto-connect on the selected port always in the future (you can change that later on if you wish).

LogWorks can also be started by dragging one or more log files on the LogWorks icon (if you installed one on the desktop). In this case the log files will be opened automatically.



***Make sure no other program (including LM Programmer) is using the selected serial port.***

### 3.2 Connecting the LC-1ST to the ST-12 and Calibration

**Note: The calibration process can be done with multiple LC-1STs at one time**

Connect the DB-15 connector from the LC-1ST to the ST-12.

- 1 Do not connect the sensor to the LC-1ST yet.
- 2 Switch ON the power supply on the ST-12. You should see the following screen in LogWorks:

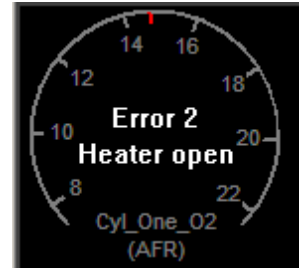

- 3 Switch off the power supply after 10 seconds.

- 4 Connect the sensor to the sensor interface connector on the LC-1ST. **The sensor must be exposed to free air (outside of the exhaust) for the first time calibration.**

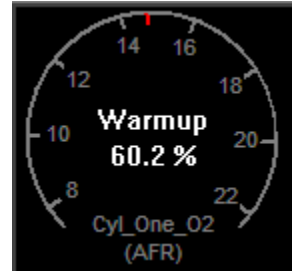

- 5 Switch ON the power supply on the ST-12. After the sensor is warmed up, the LC-1ST automatically calibrates the sensor heater controller to the particular sensor. During this 20-second period the LC-1ST collects and calculates sensor specific data required to quickly reach operating temperature in the future.

During the heater calibration the screen will show a "Htr Cal" count down from 9 to 0.



- 6 Press the Calibration button for the LC-1ST on the front of the ST-12. The LC-1ST will now calibrate itself by using air as a reference gas with known oxygen content. After the calibration period is over (2-3 seconds), the instrument is ready to operate.



In general, it's only necessary to calibrate the sensor heater the first time you use a new sensor, while the free air calibration is required more frequently. Free air calibration will correct for: 1) A change in atmospheric pressure (i.e. going from sea level to 6,000 ft. above for a race); or 2) Sensor wear (i.e. regular use for hundreds of hours).

Heater calibration detects and stores the impedance characteristics of a new sensor. Generally these characteristics don't change with wear, however some forms of carbonization can impact the impedance of the sensor. The most common problematic carbonization comes from the use of leaded gas. If you see an error #4 (Pump cell circuit open) after using the sensor with leaded gas, you probably need to perform a heater recalibration. If you use sensor regularly with race gas, we recommend keeping a backup sensor, and performing heater recalibrations more frequently.



The Heater Calibration and Free Air Calibration are unique to each sensor. If you use a different sensor on a LC-1ST you will need to run through the whole Calibration procedure again (section 3.2)!

### 3.3 Selecting internal sensors.



Table 1:  
Input  
Functions

#### Input 1 Functions

Function Indicator	1	2	F	d	=
Functionality	RPM (0..10230)	RPM (0..20460)	Frequency (straight frequency, Speed sensor, Custom RPM range)	Duty Cycle	External 0..5V sensors

#### Input 2 Functions

Function Indicator	1	2	=
Functionality	Thermocouple EGT range (0..1093 degC, 32..1999 degF)	Thermocouple CHT range (0..300 degC, 32..572 degF)	External 0..5V sensors

#### Input 3 Functions

Function Indicator	1	2	F	=
Functionality	Duty Cycle	Ignition Timing	Frequency (straight frequency, Speed sensor, Custom RPM range)	External 0..5V sensors

**Input 4 Functions**

Function Indicator	1	2	3	4	F	d	=
Functionality	MAP (1 bar) (0..101.3 kPa)	MAP (3 bar) (0..304.1 kPa)	Vaccum (0..30 inHg Vacc)	Vaccum/Boost (-14.7PSI... 29.4 PSI)	Frequency (straight frequency, Speed sensor, Custom RPM range	Duty Cycle	External 0..5V sensors

**Input 5 Functions**

Function Indicator	F	d	=
Functionality	Frequency (straight frequency, Speed sensor, Custom RPM range	Duty Cycle	External 0..5V sensors

To program an input channel, repeatedly press the 'Channel' button until the channel number to program appears on the ST-12 digit display. Then repeatedly press the 'Function' button until the digit display shows the intended function. The digit display will switch rapidly between indicating the input channel number and the set function. The LEDs next to the channel and function buttons will indicate which value is being displayed.

If the function selected is External input, the digit display shows a '='.

**4 LC-1ST**

**4.1 Calibration**

There are two types of calibration for the LC-1ST: free air calibration and sensor heater calibration. Sensor heater calibration is automatically performed the first time a new sensor is used and the free air calibration can be triggered from the "calibrate" button in from of the ST-12.

**4.2 Free air calibration**

To achieve maximum precision, the LC-1ST and its sensor needs to be recalibrated frequently with the sensor outside of the exhaust.

**The sensor MUST be operated in free air for calibration.**

Remove the oxygen sensor and expose the sensor to air (away from the exhaust) for calibration purposes:

- 1 Connect the LC-1ST to the ST-12 and switch it on.
- 2 After the sensor has warmed up, press the pushbutton.

If a LED indicator on the face of the ST-12 will be off during the free air calibration.

### **4.3 Sensor heater calibration**

If you change the sensor – either with a replacement sensor or a new type of sensor --, the heater circuit of the LC-1ST needs to be recalibrated as well. (See steps in chapter 3 'First Time Use'). The heater calibration data in the LC-1ST will be reset when the device is operated from ST-12 without a sensor connected for at least 5 seconds. You can force a reset by doing this, and then recalibrate by turning the unit off, reconnecting the sensor, and turning the ST-12 on.

After the sensor is warmed up the ST-12 automatically calibrates the sensor heater controller to the particular sensor. During this 20-second period the LC-1ST collects and calculates sensor-specific data required to quickly reach operating temperature in the future.

**Note: When using the Bosch Sensors the LC-1ST may perform multiple calibration passes. This is normal and need not cause concern. When it completes, the LC-1ST also will perform a free air calibration. Make sure the sensor is operating in free air for the heater and free air calibration.**

### **4.4 Sensor Location**

***Using a bung is the preferred method for mounting the O<sup>2</sup> sensor for both catalytic and non-catalytic cars.***

**On CATALYTIC CONVERTER equipped vehicles:**

Install the oxygen sensor's bung upstream from the catalytic converter (a bung and plug is included in the LC-1ST kit). Any decent muffler or exhaust shop can do this for you. The wide-band oxygen sensor is then installed into the bung to take a reading. (Insert the plug into the bung when not in use). **The bung must be installed in the exhaust pipe at the side or on top, NOT on the bottom of the exhaust pipe.** Best position is between 10:00 and 2:00 position.

**On NON-CATALYTIC converter vehicles:**

You have the option with non-catalytic cars to also use a Bung as described above. Use of a bung is the preferred method for mounting the O<sup>2</sup> sensor for both catalytic and non-catalytic cars.

**On TURBO CHARGED vehicles:**

Install the bung downstream from the turbo before the catalytic converter. The high exhaust pressure before the turbo interferes with the lambda measurement and the high exhaust temperatures encountered there can damage the sensor.



**Sensor placement before the turbo is not recommend because of negative effects caused by back pressure and high temperatures.**



**Do NOT install the Bung below the 3 o'clock or 9 o'clock position. Condensation can form in the exhaust pipe and permanently damage the sensor. 6 o'clock is the absolute worst position to mount the sensor.**



**Wide band oxygen sensors – like the one shipped optionally with the LC-1ST – are designed to work with unleaded gasoline. Using them with leaded gasoline will significantly reduce the lifespan of the sensor. The reduction is directly proportional to the metal content of the fuel. In most cases, a wide band sensor will provide accurate measurements somewhere between 50 hours and 500 hours with leaded fuel.**



**WHEN INSTALLED IN THE EXHAUST, THE OXYGEN SENSOR MUST BE CONNECTED AND OPERATING WITH THE LC-1ST WHENEVER THE ENGINE IS RUNNING. AN UN-POWERED OXYGEN SENSOR WILL BE DAMAGED WHEN EXPOSED TO EXHAUST GAS.**



**The maximum temperature of the sensor at the bung (the sensor hexagon) should not exceed 500 °C or 900 °F. If these temperatures are exceeded in your application install the Innovate Motorsports' Heat-Sink Bung extender (HBX-1). The bung extender is recommended for situations where airflow is restricted or the encountered heat is higher than a heat sink can handle.**



**Depending on the climate and the sensor position in the exhaust, condensation water can form in the exhaust pipes. This condensation water could then be blown by the exhaust stream against the hot sensor when the car is started. The resulting heat shock can permanently damage the sensor.**

#### 4.5 HBX-1

It is highly recommended that on high output engines, or engines running on race gas (leaded fuel) use the HBX-1 accessory on each sensor.



#### 4.6 Programming the LC-1ST

You must program each LC-1ST individually. You can accomplish this by plugging in each LC-1ST to the DB-15 connector in a backwards order. For example, if you need to program eight LC-1STs you would connect the LC-1ST going into cylinder #8 into the 8 connector and program it first. Once you finish programming the LC-1ST you will need to cycle power (turn off the ST-12 then turn it back on) and move on to the LC-1ST in cylinder # 7 so on an so forth until you reach the last LC-1ST in cylinder # 1.



***Make sure no other program (including LM Programmer or LM-1 Manager) is using the selected serial port.***

Start the LM-Programmer software. The screen should look like this:

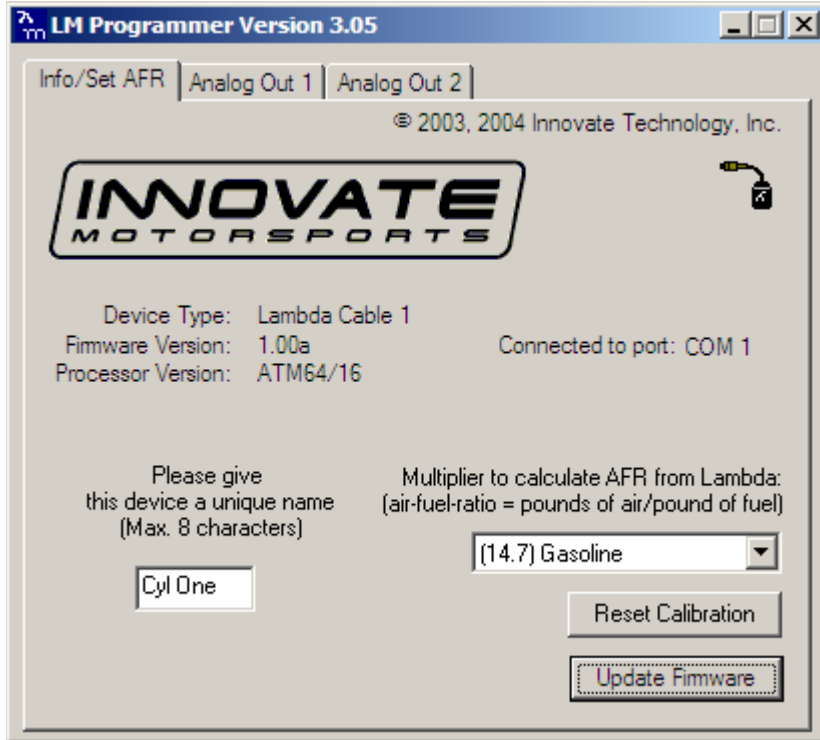

On this page you can see the software version of the LC-1ST and you can change the multiplier to calculate AFR from Lambda. A number of different multipliers are already pre-selectable but you can change it to a custom one for the particular fuel you are using.

If you plan to use multiple LC-1ST's, change the device name to something identifying which LC-1ST is connected where. For example LC1-Cyl1 for a LC1 connected to Cylinder 1. The device name can be up to 8 characters long.

#### 4.6.1 Resetting the calibration data

Press the Reset Calibration button if you want to reset all calibration data in the LC-1ST. This will clear all calibration data of the LC-1ST.

#### 4.6.2 Updating the Firmware

Click the 'Update Firmware' in the main page to upgrade to the latest *firmware* for the LC-1ST. Firmware for the LC-1ST has the extension dld. You can also download the latest firmware and software (LM Programmer and Demo) from the Innovate! Motorsports web-site at

<http://www.tuneyouengine.com>

If your computer crashes during a firmware upgrade, the LC-1ST has a recovery mechanism where it will be able to retry the download again and not be disabled by half loaded firmware. Switch the LC-1ST off and on again and then try to restart the LC1 Manager software. The recovery mechanism is designed to be able to recover 99.9% of the time. While we don't anticipate this occurring, it is possible that the LC-1ST will not recover correctly and may need to be serviced at our factory. If you suspect this is the case, contact Innovate support.

#### 4.6.3 Programming the analog outputs

Select one of the Analog output tabs. The Analog output page looks like this:

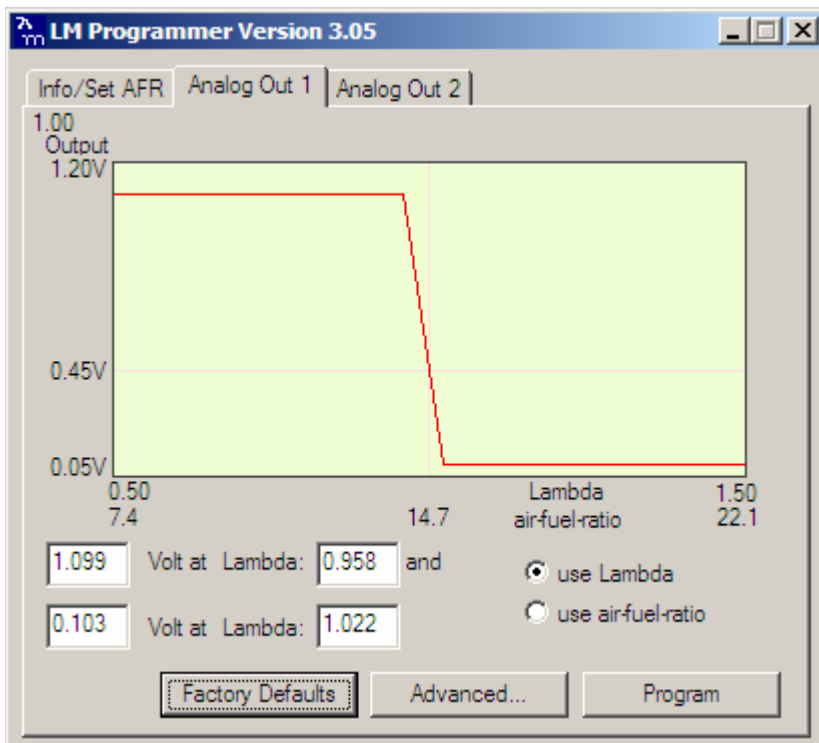

This shows the analog output voltages versus Lambda for one of the two analog outputs. The graph display is automatically scaled to the selected voltages. For each output you can specify a minimum and maximum lambda value and the associated voltages. Below the minimum and above the maximum lambda values the output voltages stay constant at the associated programmed voltage.

**By selecting the 'use Air-Fuel-Ratio' button you can program the curve by AFR instead of Lambda. This does not change the programming, only the representation of the data. When programming by AFR the LM Programmer converts the number to Lambda before programming the LC-1ST.**

Click the Program button to download the new data into the LC-1ST.

As factory programmed the first output simulates a typical narrow band oxygen sensor. The second output is programmed to output between 0 V for an AFR of 7.35 (gasoline) and 5.0V for an AFR of 22.39. Other curves of course are easily programmable

#### 4.6.4 Advanced output programming

The normal state of the analog outputs is to update the outputs every time the LC-1ST takes a new measurement. The LC-1ST is fast enough to distinguish individual pockets of exhaust gas. For many applications this will be too fast. The advanced programming allows to set the analog out update speed.

Press the "Advanced button" to set the advanced analog out settings. The following dialog box will appear:

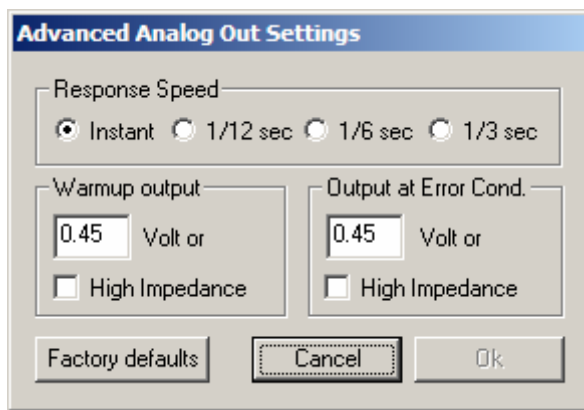

When setting the LC-1ST to the slower response speed settings the measured mixture data will be averaged over the response time setting before being output.

You can also specify what output voltage is visible on the analog outputs during warmup of the sensor and during error conditions.

The 'High Impedance' setting allows to specify that the analog outputs do not drive the output during warmup or error condition. They will be free floating. This is important for more closely simulating a narrow band sensor. Many EFI systems monitor the impedance of a narrow band sensor during engine warmup to determine sensor readiness. A narrow band sensor that's too cold will have a high impedance.

## 5 Internal Sensors

The ST-12 can be programmed directly through the setup buttons on the ST-12. LM Programmer software version 3.05 (or later) allows you to program the ST-12 via the LM Programmer software. This is necessary for some of the more advanced functionality of the ST-12. Some of these advanced functions like speed sensing, frequency sensing, custom RPM, ignition advance and so on require more user input data that cannot be supplied by the simple 3-button interface of the ST-12.

### 5.1 Connecting Type K Thermocouples

Thermocouples are used to measure temperatures by relying on the phenomena where a junction of any two different metals (Copper and Iron, for example) will generate a small voltage. This voltage is dependant upon which two metal are used, and the temperature of the junction. This phenomena is known, formally, as the "Seebeck Effect". Because every junction of different metals contributes its own voltage into the measurement, it is important to have as few junctions between dissimilar metals as possible in order to record an accurate measurement. This is why thermocouple wire is made completely of two different metals. The "Type K" thermocouple included in the ST-12 kit is composed of Cromel and Alumel; one lead being made of each (the red and yellow leads). ***Do not look in the box for a thermocouple sensor to put onto the end of the thermocouple wire. You can use the wire AS the sensor or use the wires to attach to a Type K thermocouple.***

To make a thermocouple, strip approximately 3/4" of insulation from one end of the thermocouple wire. Twist the two exposed metal ends together. You may optionally solder them, also. But twist them first. Do not solder them in parallel. This will form what is called the "Hot junction". This "Hot junction" is what you will connect to the surface that you want to measure. This is usually either: a) under the copper gasket of a sparkplug for cylinder head temperature (CHT) or, b) clamped to a primary header tube for exhaust gas temperature (EGT).

There is also the "Cold junction." This is where the 2 leads of the thermocouple come together again at the ST-12 terminals. The ST-12 has an internal temperature sensor at the T/C input terminals. It uses this sensor to "offset" the effect of the "Cold junction" in the measurement. This is called "Cold junction compensation". Once the effects of the cold junction are neutralized, the ST-12 can accurately read the temperature of the "Hot junction" which is the twisted lead pair at the opposite end of the thermocouple wire.

One thing that is confusing for many people is that the *negative side of a thermocouple wire is always red*. There are many different types of thermocouple wire; types K, J and T being the most popular. All have a red negative lead and a yellow, black, or blue positive lead respectively. **When connection the thermocouple to the TC terminals on the ST-12, be sure to connect the yellow lead to the + and red lead to the - terminals.**

Several manufacturers offer EGT "thermocouple probes" which are actually inserted into the exhaust gas stream through a hole in the headers or exhaust manifold. These provide a more accurate measurement of exhaust gas temperature. They are commonly available in types K and J. Only type K will currently work with the ST-12. To use a thermocouple probe, connect the red and yellow leads of the thermocouple wire to the yellow and red leads of the thermocouple probe. The junction is inside the probe. **You can not use normal copper wire to connect the thermocouple probe to the ST-12.** You must use thermocouple wire to connect the probe. If you do not, there will be an extra two-metal junction

where the Copper wire meets the Constantan wire of the probe. This extra junction will cause a large error in the temperature readings.

Most Thermocouple probes are of the “grounded junction” type. This means that the “hot junction” is also connected to the probe’s body. As this body is connected for example to the exhaust manifold, the sensor wires are essentially grounded through that. The same is true if a home-made thermocouple junction is used as described above by twisting the wires and if that wire-twist is connected to some grounded engine part.

You can check if you have a grounded junction type by measuring between the probe body and one of the Thermocouple wires. If you have continuity, you have a grounded junction.

## **5.2 Connecting an RPM signal**

For RPM measurement you can either connect a tach signal to the CH1+ input or plug an inductive clamp into the 3.5 mm stereo socket marked RPM. See chapter 6 for RPM measurement details.

### **5.2.1 Using the Variable Potentiometer**

1. Turn the potentiometer all the way to the right. (until RPM light goes out )
2. Slowly turn the potentiometer to the left until the RPM light starts to flicker
3. Keep turning until the RPM light goes solidly on.
4. Turn the potentiometer an additional amount roughly equal to the distance between where the light 1st came on and where it went solidly on.

### **5.2.2 RPM Measurement basics**

Most RPM measurement methods use the ignition system of the car as a convenient source of RPM dependent pulses. Other methods use a TDC sensor (one pulse per rotation), cam sensor, or fuel injection pulses (number of pulses/rotation is dependent on the fuel-injection system). Some actually measure the AC frequency created by the car's alternator.

Because the number of pulses per crank rotation is dependent on the ignition system and engine type, a universal RPM measurement method must be adaptable to the different environments encountered. The typical ignition system consists of an ignition coil, a coil driver that switches current to the coil on and off, and a distributor. When current is switched on to the coil, the coil stores energy in its magnetic field. When the current is switched off, that energy gets discharged at a very high voltage pulse on the coil’s secondary winding, creating a spark.

A capacitive discharge ignition system (CDI) uses a capacitor to store the spark energy. The capacitor is charged to about 400V and then rapidly discharged over the ignition coil's primary winding. The coil thus only acts as transformer and does not store energy (and can therefore be smaller). The advantage of a CDI system is a very high and fast rising spark voltage (less susceptible to spark fouling). The weakness of the CDI system is the very short duration spark, which might not be long enough to ignite the mixture. Multispark ignition systems try to overcome the inherent weakness by creating multiple spark pulses over some degrees of crank rotation to increase the likelihood of igniting the mixture. The distributor switches the spark voltage to the appropriate spark plug.

### **5.2.3 Four-Stroke Engines**

On a typical 4-stroke engine each spark plug fires once for every two crank rotations. The coil on a distributor-equipped 4-stroke has to create sparks for every cylinder. The number of ignition pulses per crank rotation in this case is the number of cylinders divided by 2.

Some engines have one coil for every 2 cylinders instead of a distributor. The coil fires two spark plugs at the same time. One spark is wasted because it fires one cylinder at the end of its exhaust stroke. Therefore, this system is called a Waste Spark System. Each coil of a Waste Spark System fires once for every crank revolution.

Other distributor-less 4-stroke engines use one ignition coil for every spark plug. This ignition system fires each coil once for every 2 crank revolutions.

Coil-on-Plug ignition systems actually incorporate the ignition coil in a module that plugs directly onto a spark plug and do not have a spark plug wire.

#### **5.2.4 Two-Stroke Engines**

On a 2-stroke engine there is a spark for every crank rotation, so the spark frequency doubles compared to a 4-stroke. Very few multi-cylinder 2-strokes have distributors. For those that do, the number of ignition pulses per crank rotation is equal to the number of cylinders. Most two-stroke engines have one coil for every cylinder. The coil fires once for every crank revolution, the same as on a 4-Stroke Waste Spark system.

#### **5.2.5 Rotary Engines (Wankel Engine)**

A rotary engine consists of a roughly triangle shaped rotor rotating in a roughly elliptical chamber. The three spaces left between the chamber and the rotor go through the four cycles of a four-stroke engine for each rotation of the rotor. A single (or dual) spark plug at a fixed position in the chamber ignites the mixture of each space in sequence. Therefore, a rotary engine requires 3 sparks for every rotation of the rotor. The mechanical power from the rotor is coupled to an eccentric gear to the output shaft. This gear has a 3:1 gear ratio and the output shaft therefore rotates 3 times faster than the rotor. The output shaft is the equivalent of the crankshaft on a piston engine. Because RPMs are measured conventionally as the rotations of the crankshaft, the rotary engine requires one spark for every 'crankshaft' rotation, the same as a two-stroke engine.

#### **5.2.6 How the ST-12 determines RPM**

The ST-12 measures RPM not by measuring the number of pulses over a time period, as a tachometer does. That measurement would be too slow to provide adequate correlation between input channels. Instead the ST-12 measures the time between input pulses and from that calculates RPM for each pulse measurement.

This measurement method has a few caveats though:

1. If the RPM pulse signal is derived from the ignition signal, a multi-spark ignition system will trigger the measurement multiple times for each pulse. This throws the measurement off because the ST-12 does not know if the pulses are for each ignition event (one per cylinder cycle) or because of multispark. This is especially problematic because the number of multispark pulses also varies with RPM in a lot of ignition systems. Fortunately many multispark ignition systems output a tach signal with only one pulse per engine cycle. But some, notably Ford EDIS systems, output all pulses and therefore require a special tach adapter.
2. Odd fire engines, like V-Twin motorcycle engines and odd-fire V6 engines have ignition pulses that are not evenly spaced. For example a 60 degree V-Twin running at 10 degrees ignition

advance will fire cyl. 1 at 10 degrees BTDC. Then fire cyl. Two 420 degrees later at 410 degrees. Then fire cyl 1 300 degrees later at 710 degrees. This means the ignition pulses sent to the ST-12 are alternating between 420 and 300 degrees apart and therefore the time between pulses alternates. The ST-12 therefore measures the times between ALL pulses for a complete engine cycle (2 rotations) and averages the times between them.

### 5.2.7 Programming the RPM input

- Determine the number of ignition pulses per crank rotation. Refer to Table 2 or 3 for guidance.
- Press the 'Channel' button until it shows channel 1.
- Press the 'Function' button until it shows 1 or 2. Use 1 if your engine's redline is below 10000 RPM. Otherwise use 2.
- Press the 'Calibrate' button until the selected Cyl. Number appears

*Table 2: Cylinder number and RPM calibrate number 4-stroke engine*

Number of Cylinders	4-Stroke pulses/Crank-Rotation	Calibrate Number	Comment
1	1/2	1	Use also when using inductive clamp on spark wire or power wire of COP system of 1 cylinder only for all cylinder numbers
2	1	2	Use also when using inductive clamp on spark wire or power wire of Waste spark coil of 1 cylinder only. Waste spark system: 1 coil for every 2 cylinders.
3	1-1/2	3	
4	2	4	
5	2-1/2	5	
6	3	6	
8	4	8	
10	10	A	
12	12	C	

*Table 3:: Cylinder number and RPM calibrate number 2-stroke and Rotary Engine*

Number of Cylinders	2-Stroke pulses/Crank-Rotation	Calibrate Number	Comment
1	1	2	Use also when using inductive clamp on spark wire or power wire of COP system of 1 cylinder only for all cylinder numbers Also use for rotary engine.
2	2	4	Use also when using inductive clamp on spark wire or power wire

			of Waste spark coil of 1 cylinder only. Waste spark system: 1 coil for every 2 cylinders.
3	3	6	
4	4	8	
5	5	A	
6	6	C	

### 5.2.8 Using the ST-12 with the Inductive Clamp

The inductive clamp measures the magnetic field created around a spark plug wire when spark current flows. If a metallic shield covers the spark plug wire, the inductive clamp may not work because the shield would short out the magnetic field. Like all inductive clamp rpm pickup devices, some ignition systems like Capacitive Discharge Ignition (CDI) or multi-spark ignition systems may not work properly with the inductive clamp pickup because the pulses created may be too short in duration. Multi-spark systems confuse the ignition timing measurement because the RPM converter cannot distinguish which ignition pulse belongs to which crank rotation. **The ST-12 will work only on the tach output of the ignition system in this case.**

**The inductive clamp must be clamped around ONE lead only. Clamping it (for example) around all wires of a coil-on-plug pack does not allow it to work because the magnetic fields of the wires most likely cancel each other out.**

### 5.2.9 Inductive Clamp Usage

- Plug the inductive clamp's 3.5mm audio plug into the RPM socket of the ST-12.
- Clamp the Inductive Clamp on the spark plug wire of one cylinder so the wire is completely surrounded by the clamp.
- Make sure the clamp is completely closed.
- Start the engine.

The decimal point of the digit display of the ST-12 should light up steadily. This indicates when a valid RPM signal is detected. If it does not light up, or lights up intermittently, reposition or reverse the clamp (try clamping it upside down). If the decimal point out only occasionally, that is OK. The RPM converter will still convert, though its output might be noisy. A noisy output has spikes or lengthy flat areas in the data log. *[Note: to work properly with the inductive clamp pickup the ST-12 must be set up for the appropriate number of pulses per crank rotation.]*

- For a 4 stroke engine without waste spark ignition, this would be 1 pulse per 2 crank rotations. This is the factory setting.
- For a 4 stroke engine with waste spark ignition, or a 2 stroke engine, this would be 1 pulse per crank rotation.
- For a rotary engine, this would be 1 pulse per rotation. This is the same as for a 1-cyl 2-stroke motor.

***Note: On any distributor-less ignition system you can alternately clamp the inductive clamp around one of the power wires on the primary side of the ignition coil or coil-on-plug module.***

### 5.2.10 Using the RPM-Converter with pulsed RPM input (Tach) signals

- Unplug the inductive clamp from the ST-12 if connected.
- Connect the RPM signal to the CH1+ input screw terminal.

The decimal point of the digit display of the ST-12 should light up steadily. This indicates when a valid rpm signal is detected. If it does not light up, check your connections.

***DO NOT CONNECT A PULSED RPM SIGNAL TO THE INDUCTIVE CLAMP INPUT. THIS MIGHT DAMAGE THE ST-12 OR LM-1. Again, this should just result in an error code, not mechanical damage.***

## 5.3 Measuring Pressures

The ST-12 has a built in MAP sensor. To use it, connect a small ¼" hose between a vacuum/boost connection AFTER the throttle body and the ST-12 MAP input port.

It should be connected after the throttle body because the lowest pressure that can be measured before the throttle body is atmospheric pressure (discounting some pressure losses from the intake tract before the throttle body).

MAP stands for Manifold Absolute Pressure. This means that the sensor measures pressure referenced to absolute vacuum, not atmospheric pressure like many vacuum and boost gauges.

Engine parameters like fueling, ignition timing, compressor efficiency and so on are dependent on the MASS of air (in pounds per cubic foot or kg per cubic meter) entering the engine. As air is a gas, it's mass is dependent on it's ABSOLUTE pressure, referenced to absolute vacuum and it's temperature. Most vacuum and boost gauges are gauge pressure sensors. A gauge pressure sensor measures the difference to atmospheric pressure, not the absolute pressure. So, without knowing atmospheric pressure at the point where the sensor gets it from, the actual air-mass entering the engine can't be measured. Because the atmospheric pressure changes with altitude and weather, the gauge pressures are not a precise metric. This is specially problematic for boost pressure sensors, because their atmospheric reference source comes typically from inside the cabin or engine compartment. The atmospheric pressure there can change with speed from aerodynamic effects (ram pressure).

### 5.3.1 Measuring MAP

Function 1 of input 4 of the ST-12 measures absolute pressure with a range of 0..1 bar (0..14.7 PSia). This is the range intended for normally aspirated engines where the maximum intake pressure can be atmospheric pressure.

Function 2 of input 4 of the ST-12 measures absolute pressure with a range of 0..3 bar (0..44.1 PSia). This is the range intended for boosted engines where the maximum intake pressure can be up to 29.4 PSI above atmospheric pressure.

### 5.3.2 Measuring boost/vacuum

The ST-12 can use it's MAP sensor also as gauge pressure sensor if so desired. As stated above, this is NOT the preferred way of measuring pressures, but it is possible. The ST-12 will measure the current atmospheric pressure in the intake tract when it starts up and stores this value internally until it is started

the next time. In vacuum/boost measurement mode the ST-12 will then subtract the measured value from the MAP value internally.

Function 3 of input 4 of the ST-12 measures vacuum with a range of 0..30 inHg (gauge) This is the range intended for normally aspirated engines where the maximum intake pressure can be atmospheric pressure.

Function 4 of input 4 of the ST-12 measures vacuum and boost pressure with a range -14.7 to 29.4 PSiG This is the range intended for boosted engines where the maximum intake pressure can be up to 29.4 PSI above atmospheric pressure. Vacuum is typically measured here as negative PSI. But you can set up any metric you want with LogWorks 2.

#### **5.4 Measuring Ignition Advance**

##### **Warning:**

***Measuring ignition advance is NOT a simple plug-and-play process. The variables are many and you need to know what you are doing to do it right. Read this chapter multiple times before attempting this and try to understand what you are measuring.***

**The ST-12 expects the spark reference pulse on input 1 and the crank reference pulse on input 3.**

**Input 1 is simultaneously still used to measure RPM, but MUST be set to measure RPM.**

**The ST-12 can measure ignition advance between 10 degrees ATDC to 50 degrees BTDC. ATDC numbers will be negative, BTDC numbers will be positive. The LogWorks equivalents are 0V = -10 degrees, 5V = 50 degrees.**

Ignition advance is typically measured in degrees. This is the number of degrees before Top-dead-center of a piston where the spark fires.

When the spark in an engine fires the mixture in the combustion chamber starts the burn process. Because it takes time for the fire to consume the mixture, it has to be lighted before the piston hits top dead center. During that burning process the pressure and temperature rises. The pressure and temperature rise results not only from the energy released by the burning mixture, but also the piston is still moving up, compressing the burning gas. At some point in this process the pressure in the cylinder peaks and then falls off. The position of this pressure peak (in crank angles) depends on the engine geometry (bore-stroke ratio, stroke-rod length ratio and so on), but NOT on engine load or RPM. For many engines the ideal peak pressure position to extract the maximum energy is between 14 and 20 degrees ATDC.

The time the mixture takes to burn is dependent on many variables. AFR, mixture density, temperature and so on are some of the variables. The point of ignition advance is to time the spark such, that the peak pressure point is reached at the ideal position. Earlier or later loses power.

An engine typically does not have a "crank degree" sensor output of sufficient resolution. Therefore ignition advance must be measured as a time measurement. An engine crankshaft rotates at 360 degrees per revolution. So, by measuring the time between the spark pulse and a reference pulse, the ignition advance time can be calculated.

For example if the reference pulse is at a 90 degree crank angle and the spark happens at 20 degrees BTDC at 6000 RPM, the engine rotates at 36000 degrees per second. So, the time difference between spark pulse and reference pulse is 0.003055 seconds.

Most modern EFI systems have trigger wheels that create reference pulses through a hall effect or variable reluctance sensor. These trigger wheels look like toothed gears with one or two teeth missing (some instead have extra teeth).

Some systems also have only a single magnetic trigger reference from the flywheel or balancer and use the starter ring gear to provide extra pulses. The extra pulses are needed by the ECU to determine the exact crank angle when to fire the sparks for the different cylinders.

The ST-12 is not concerned with firing multiple cylinders, but only with the timing of one cylinder (typically cylinder 1). Therefore it does not need the additional pulses, but can identify the reference trigger from each.

Another concern is the “phase” of the pulses. The timing can be measured either from the rising or falling edges of the spark pulse to the rising or falling edges of the reference pulse. Which pulse edge for each has to be known to allow accurate measurement. Very often this can be only determined by trial and error. This means you have to go through all four possible combinations until you measure the correct advance, verified with a timing light.

For this reason the use of the inductive clamp as RPM source is NOT recommended for spark advance measurement, because it's phase is indetermined can changes depending on which way around you use the clamp.

For example if the source for the spark pulse is the negative side of the ignition coil (inductive ignition), the negative side of the coil goes to ground (negative edge of pulse) to charge the coil. When the coil discharges (spark happens) the voltage rises to severall hundred volts and then returns to 12V. In this case the spark pulse would use the rising edge.

The same is true for the trigger pulse from the trigger wheel. Depending on the sensor used, the output pulses can be negative or positive. This can either be found out with an oscilloscope or by programming the ST-12 for one way or the other and finding out which is the correct one.

The tryout should be done at different RPMs, because under some circumstances you could get a correct reading at idle, but a shift at a different RPM.

**NOTE:**

**Variable reluctance sensors cannot be read by the ST-12. VR sensors do not output a clean pulse, but a short wave, whose 0 Volt crossover is measured. The wave amplitude is dependent on RPM and sensor. For these applications a special VR amplifier like the LM1815 needs to be used.**

Example voltage trace of a VR sensor output:

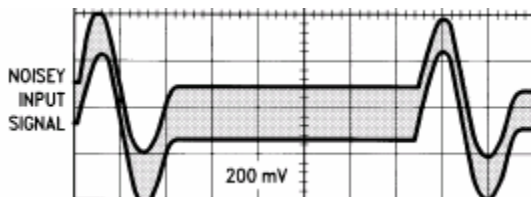

Example output of a VR sensor amplifier:

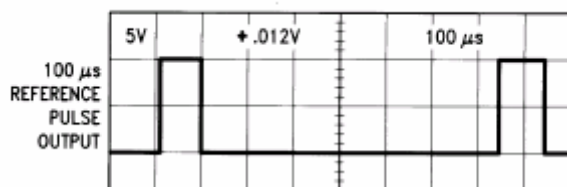

As one can see, the reference pulse created would have a positive edge.

### 5.4.1 Making your own optical reference pulse sensor

The device to be used is a Fairchild reflective optical sensor type QRC1133. This device contains an infrared LED to shine an infrared light beam on a mark on the balancer or flywheel and also contains a photodiode to detect the reflected light. The device can be ordered from:

[www.digikey.com](http://www.digikey.com) Part Number QRC-1133-ND.

This device looks like this:

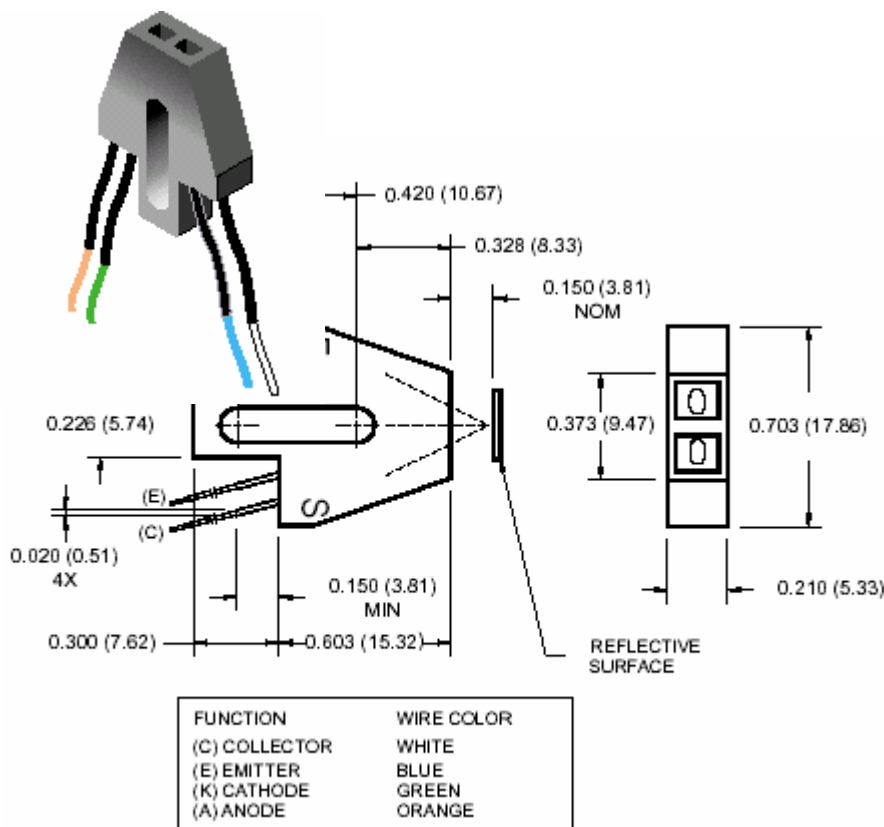

To use it you also need two resistors (1/4W). One resistor is 330 Ohm, the other 3.3 kOhm. The hookup schematic to be used is this:

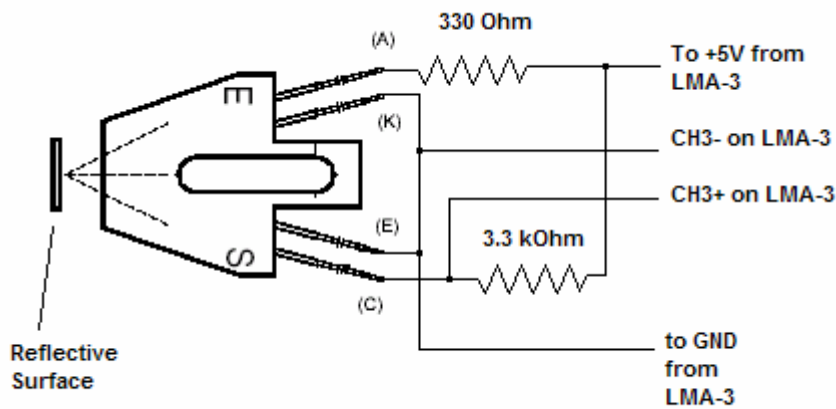

Paint the balancer or flywheel surface flat black so as not to reflect any light. Then paint a ¼" (6 mm) white stripe on the balancer or flywheel at 90 degrees after TDC. The edge of the stripe in rotation direction should be at the 90 degree mark. The sensor should be mounted at TDC where the TDC mark is when the engine is at TDC.

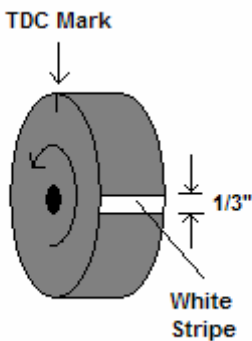

The device will output a pulse with the **NEGATIVE** edge at the 90 degree mark. Mount the device so that its front edge is about 0.15" (3.8 mm) from the flywheel/balancer. The LED shines infrared light on the flywheel balancer, but the light is absorbed by the black surface. So the photodetector in the device is off and the CH3+ connection should be between 3 and 5V. If the voltage is lower, replace the 3.3 kOhm resistor with a lower value, but don't go below 1 kOhm. When the LED shines on the white stripe, light is reflected and the photodetector is on, drawing current through the 3.3 kOhm resistor. The voltage at the CH3+ connection should be less than 1 Volt. If the voltage is higher, replace the 3.3 kOhm resistor with a higher value.

### 5.5 Measuring Frequencies, custom RPM, or speed

The ST-12 has the capability to measure frequencies on any input except input 2. It converts a frequency signal (pulses per second) into a voltage (0..5V) to be logged in the LM-1 or a number between 0 and 1023 to be logged directly by LogWorks. This is useful for measuring custom RPM ranges, signals from speed sensors or the frequency of MAF sensors with frequency output (as opposed to voltage output MAF sensors).

The range of frequencies that the ST-12 can measure can be programmed by with LM Programmer. The ST-12 can be set to any frequency range between 0 and 10 Hz for the full 0..5V range to 0..15 kHz for the full 0..5V output (logging) range.

Also, LM Programmer has convenient conversions built in, so you don't have to calculate the resulting frequency ranges for speed sensing or RPM sensing yourself. See chapter 10.x for details. A frequency input signal must have an amplitude (voltage range of pulse) between 0.5V at the low pulse point to minimum of 3V and maximum of 40 V at the high pulse range.

**NOTE:**

***The custom RPM feature will work only for even fire tach signals, not for tach signals that vary their time between pulses during an engine cycle. Use the input 1 RPM functions instead.***

## **5.6 Measuring duty cycle**

To measure the duty cycle of a signal (on any channel except channel 2), the input signal must cover the same voltage range as for a frequency signal. Duty cycle is defined as the ratio between the time a signal is active and the total time of the active and inactive time. A signal can be either active high ( the event, like injector open, happens when there is a high voltage) or active low (the event happens when the measured signal is at ground or close to it).

Very often the injector duty cycle is to be measured by the ST-12. A typical fuel injector is connected to 12V on one side, while the other side is connected to ground when the ECU opens the injector. Because the pulse is therefore active when the voltage on the pin is at ground, negative duty cycle is measured.

So called peak-hold injectors (as opposed to saturated injectors), work differently. Their drive signal first goes to ground for a high current opening pulse, then rises to 8-10 Volts for the hold period. Because the ST-12 sees everything above 2.5V as "high", it will be able to see only the peak period. On some peak-hold systems it is possible to connect the CHx+ input of the ST-12 to 12V at the injector and connect the CHx- input to the injector signal to still measure correctly. But that is not always the case. The LogWorks 2.0 Manual shows an alternative method. If the above method works, it actually measures positive duty cycle.

## **6 Programming the ST-12**

To connect the ST-12 for programming follow these steps:

1. Disconnect all LC-1STs.
2. Connect the 2.5mm to DB 2 computer interface cable into the Serial OUT port. Your computer needs a serial port. If it does not have one, you will need a USB to serial adapter.
3. Switch the power on the ST-12
4. Start the LM Programmer application

The following screen will show up:



The LM Programmer software then shows in its first page the type and version number of the firmware of the device.

### **6.1 Changing the device name**

If multiple ST-12's are used in a Log-Chain, each MUST be given a unique name so that LogWorks can identify each ST-12. Just enter a name in the edit box in this page.

### **6.2 Updating the firmware**

Click on the 'Update Firmware' button. You will be presented with a file dialog box that allows you to select a firmware file. Firmware files end with the file extension .dld. ST-12 firmware file names start with: AUXB1 for AuxBox 1. The first part is followed by a dash, then a V, then the version number without dots.

Example: ST-12 firmware version 1.00 alpha release would have the file name AUXB1-V100A.dld LAM-3 firmware version 1.00 would have the file name AUXB1-V100.dld

After you opened the firmware file, this new firmware will be downloaded in the ST-12 device.

### **6.3 Input 1 Configuration**

Click on the Input 1 tab in the top of the window.

### 6.3.1 Measuring RPM

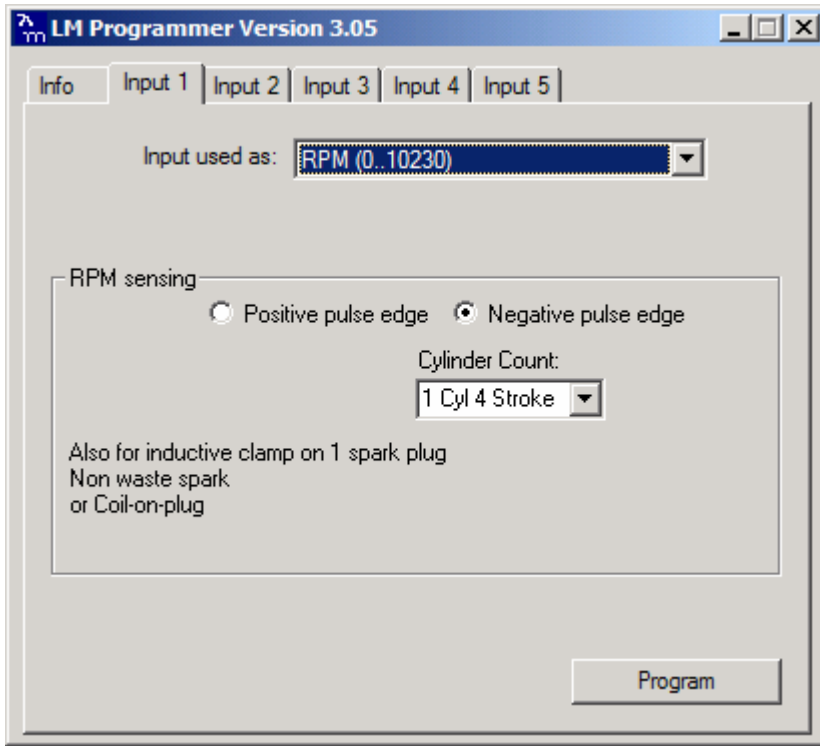

The drop-down list at the top of the window allows you to select the different functionality for that input. If RPM is selected, the area below the functionality selection shows as above.

The positive edge/negative edge selection is ONLY important if this input is also used as spark reference signal for ignition advance measurement.

Select the cylinder count in the appropriate drop-down list.

When using the custom RPM feature the center area looks like this:

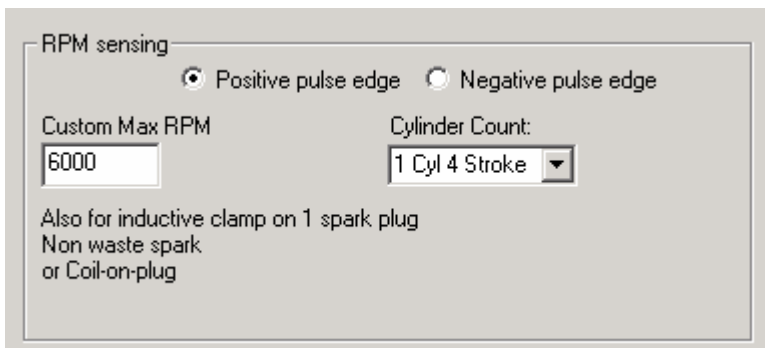

On the left edit box you can specify the max RPM for this measurement channel. In the example case the max RPM is 6000. This means that in LogWorks 6000 RPM is equivalent to 5Volt. This allows LogWorks to have a higher RPM resolution (~ 6 RPM per step instead of 10 RPM when the range is 0..10230 RPM). This functionality is also available for Inputs 3,4 and 5.

### 6.3.2 Measuring Frequency

The center section of the window changes to this:

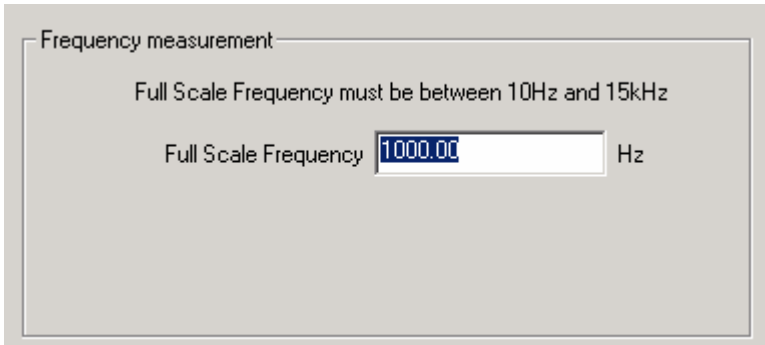

You can enter any frequency between 10 Hz and 15000 Hz as full scale frequency. ST-12 measures the frequency with a resolution of 0.1 % of the full scale frequency specified. So in LogWorks 0 Hz is always 0 Volt, and the full-scale frequency is equivalent to 5 Volt.

This functionality is also available for Inputs 3,4 and 5.

### 6.3.3 Measuring Speed

Select the Speed sensing function in the topmost drop-down list. The center section of the window changes to:

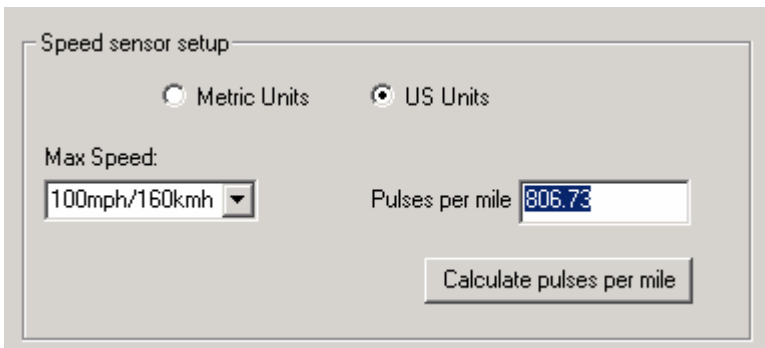

With the radio buttons you can select to use metric (km/h) or US (mph) units. In the left drop-down list you select the max speed to be measured. The ST-12 measures the speed with a resolution of 0.1 % of the selected max speed.

In the right edit box you enter the pulses per mile the speed sensor produces. Speed sensors are typically pulse sensors mounted either on the drive-shaft or wheel. To calculate the pulses per mile (or km/h) click on the calculate button:

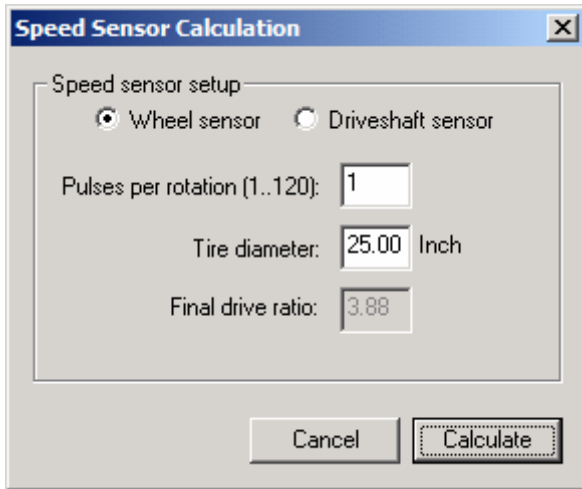

Select if you use a drive-shaft sensor or a wheel sensor. Enter the pulses per rotation created by the sensor either as driveshaft rotation or wheel rotation. You also need to enter the wheel diameter, and in case of a drive-shaft sensor, the final drive (differential) ratio. The LM-Programmer will calculate the pulses per mile (km) for you. This functionality is also available for Inputs 3,4 and 5.

#### 6.3.4 Duty cycle

See section 5.6 for details.

#### 6.4 Input 2 Configuration

Function 1 and 2 of Input 2 use the TK+ and TK- inputs. The CH2+ and CH2- inputs are used ONLY if this input is set for "external 0..5V sensor"

#### 6.5 Input 3 configuration

Input 3 has by default duty cycle measurement as function 1. See section 5.6 for details.

For Custom Frequency, Custom RPM, speed sensing and duty cycle inputs on Input 3, see chapter 11.3

When selecting ignition timing (See chapter 9 for details) for input 3, the center of the window changes to this:

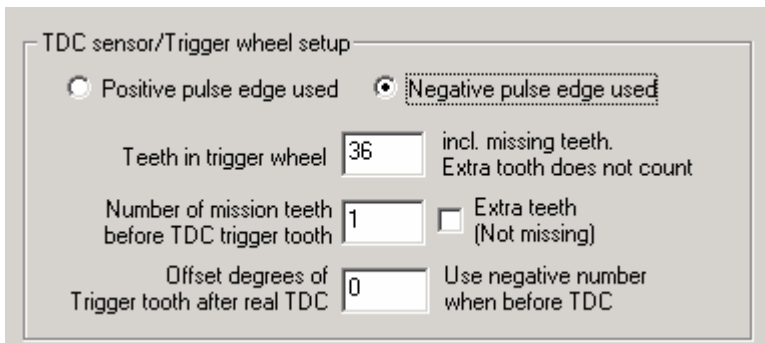

Select the trigger wheel characteristics. The trigger tooth is the tooth after the last missing tooth (if missing teeth), or the extra tooth when the wheel has extra teeth. If only one pulse is used, the missing teeth/extra teeth input is ignored.

To enter the offset in degrees, measure the offset (in degrees) after TDC after the last missing tooth. Also measure the offset of the sensor from TDC. Subtract the sensor offset from the tooth offset to get the real offset of the Trigger tooth to be entered. The following picture shows an example:

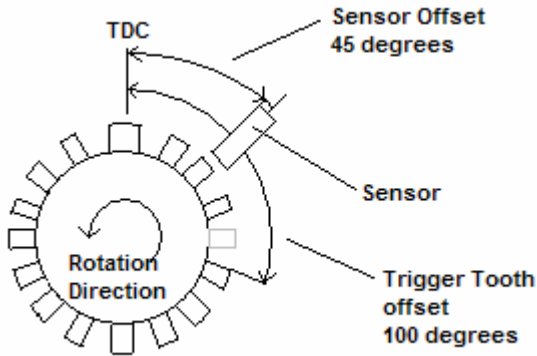

In this case the offset of the Trigger Tooth is 100 degrees (after TDC in rotation direction). The sensor is mounted at 45 degrees after TDC. So the complete real offset from TDC is 55 (100 – 45) degrees after TDC.

To measure ignition advance, Input 1 MUST be configured for RPM measurement.

### 6.6 Input 4 configuration

Function 1,2,3 and 4 on this input are used for pressure measurement. See section 5.3 for details. For Custom Frequency, Custom RPM, speed sensing and duty cycle inputs on Input 3, see chapter 6.3

### 6.7 Input 5 configuration

For Custom Frequency, Custom RPM, speed sensing and duty cycle inputs on Input 3, see chapter 11.3

## 7 Appendix

### 7.1 Error Codes

<b>Error Code</b>	<b>Error Message</b>	<b>Likely Root Cause</b>	<b>Fix</b>
<b>Error 1</b>	Heater circuit shorted	1. Short in cable 2. Short in sensor	1. Repair/replace cable. 2. Replace sensor.
<b>Error 2</b>	Heater circuit open	1. Damaged sensor cable 2. Cable connector not fully seated	1. Verify Sensor connector is fully seated into unit. 2. Repair/replace Sensor or cable.
<b>Error 3</b>	Pump cell circuit shorted	1. Short in sensor cable 2. Short in sensor 3. Sensor heater calibration incorrect 4. Sensor overheating EGT >1700° F	1. Repair sensor cable. 2. Replace sensor. 3. Perform sensor heater recalibration. 4. Move your sensor bung as far downstream as possible OR add a heatsink to isolate the sensor from the pipe.
<b>Error 4</b>	Pump cell circuit open	1. Damaged sensor cable or sensor connector not fully seated 2. Sensor heater calibration incorrect	1. Verify sensor connector is fully seated into unit. 2. Repair/replace cable. 3. Perform complete heater calibration (not just free air calibration). See section 4
<b>Error 5</b>	Reference cell circuit shorted	1. Short in sensor cable 2. Short in sensor	1. Repair sensor cable. 2. Replace sensor.
<b>Error 6</b>	Reference cell circuit open	1. Damaged sensor cable or sensor connector not fully seated 2. Damaged Sensor	1. Verify sensor connector is fully seated into unit. 2. Replace sensor
<b>Error 7</b>	General System error (typically a software error).	1. Typically a software error	1. Reboot LC-1 by cycling power. Re-flash unit if necessary.
<b>Error 8</b>	Sensor Timing error (typically a damaged sensor).	1. Sensor overheating. (The Bosch LSU4.2 is rated to operate at a sensor housing temperature of < 900 degrees (measured at the bung) for maximum accuracy and control. When this operating temperature range is exceeded, the sensor can no longer be accurately controlled. ) Sensor is damaged	1a. Perform sensor heater recalibration; 1b. Move your sensor bung as far downstream as possible. Right before the cat, or 2-3 feet from the end of the tailpipe are good locations; c. Add a heatsink to isolate the sensor from the pipe. The HBX-1 is an available accessory. 2. Replace sensor.
<b>Error 9</b>	Supply Voltage too low	Supply voltage too low for sensor regulation	Check your 12V connection for corrosion.

## 7.2 LED Blinking Codes

### 1. LED blinking codes

- a. Blinking (about) 2 times per second: **Heater Warm up**
- b. Blinking (about) 4 times per second: **Heater Calibration**
- c. LED off: **No Power or free air calibration**
- d. Steady on: **Normal Operation Indication**
- e. Blink in sequence with 2 second pause: **Error indication** (see error indication detail below)

### 2. Error indications

- a. Count the number of fast flashes between the 2 second pauses. The number of flashes indicates the error code:
  - i. 1 flash = Error 1
  - ii. 2 flashes = Error 2
  - iii. And so on, See Appendix C of the LC-1 Manual for further error code details.

NOTE: You may also use most any Normally Open (N.O.) LED-illuminated momentary push button with a 1.2 - 2.2V LED for the above process.